



Independent Statistics & Analysis
U.S. Energy Information
Administration

Addendum: Capital Cost Estimates for Additional Utility Scale Electric Generating Plants

April 2017



This report was prepared by the U.S. Energy Information Administration (EIA), the statistical and analytical agency within the U.S. Department of Energy. By law, EIA's data, analyses, and forecasts are independent of approval by any other officer or employee of the United States Government. The views in this report therefore should not be construed as representing those of the U.S. Department of Energy or other federal agencies.

Contents

Introduction	1
Findings	1
Summary	3
Table 1. Updated estimates of power plant capital and operating costs.....	4
Appendix C – Full Report.....	5

Introduction

The current and future projected cost and performance characteristics of new electric generating capacity are a critical input into the development of energy projections and analyses. The construction and operating costs, along with the performance characteristics of new generating plants, play an important role in determining the mix of capacity additions that will serve future demand for electricity. These parameters also help to determine how new capacity competes against existing capacity, and the response of the electric generators to the imposition of environmental controls on conventional pollutants or any limitations on greenhouse gas emissions.

Building on the cost and performance estimates that were developed for utility-scale electric generating plants in support of its *Annual Energy Outlook 2016* (AEO2016), EIA commissioned the same consultant to develop estimates for five additional generating technology types, including:

- Ultra-supercritical coal with 90% carbon capture and storage;
- Integrated gasification combined cycle;
- Advanced nuclear greenfield site;
- Onshore wind with Class I wind turbine generators (WTG); and
- Battery storage.

This addendum to the original report used a methodology consistent with the 2016 study and applied it to those five generating technologies.

This paper summarizes the results of the findings of the addendum to the original report and discusses how EIA used the updated information for the *Annual Energy Outlook 2017* (AEO2017) to analyze the development of new generating capacity for the electric power sector.

Findings

[Table 1](#) summarizes updated cost estimates for generic utility-scale generating plants, including two powered by coal and one each by wind, uranium, and battery storage. EIA does not model all of these generating plant types, but included them in the study in order to present consistent cost and performance information for a broad range of generating technologies and to aid in the evaluation for potential inclusion of new or different technologies or technology configurations in future analyses.

The specific technologies represented in the NEMS model for *AEO2017* that use the cost data from this report are identified in the last column of [Table 1](#).

Additional technologies covered in the report addendum include:

- **Ultra-supercritical coal with 90% carbon capture and storage (USC/CCS90):** As a result of the new source performance standards (NSPS) specified under Section 111(b) of the Clean Air Act (CAA), EIA assumed that new coal plants cannot be built without CCS for *AEO2017*. A new highly-efficient USC

coal plant can currently achieve an emission rate of 1,700 lbs CO₂/MWH, so with 30% carbon sequestration it is assumed to be compliant with the NSPS regulation (at 1,400 lbs CO₂/MWH.) The plant configuration for the USC with 90% CCS Facility is similar to the 30% USC with CCS technology in the November 2016 Capital Cost Estimates for Utility Scale Electricity Generating Plants report, with two exceptions: (1) an amine scrubbing system to capture CO₂ from the flue gas, and (2) the scaling of the boiler to a larger size, approximately 130% the size of the boiler in the USC Facility. The assumed carbon capture was set at 90%, and is available in the model for scenario analyses that may require higher levels of carbon reduction.

- **Integrated gasification combined cycle (IGCC):** The IGCC Facility is a nominal 618 MW net coal-fired gasification-to-power facility. The power block for the IGCC Facility case is based on a two-on-one combined-cycle configuration using F-class combustion turbines (CTs), each with a nominal output of 232 MW. The combined cycle is similar to the conventional combined cycle unit in the November 2016 Capital Cost Estimates for Utility Scale Electricity Generating Plants report, except the CTs are designed to combust natural gas and/or syngas, and the combustors are not configured for dry low-NO_x combustion. The IGCC as represented here is not among the generating technologies modeled by EIA in *AEO2017*, and while it does not include any control devices for CO₂, it contains a system for acid gas removal, so its configuration could be modified to capture CO₂ at a later time.
- **Advanced nuclear greenfield site (ANGF):** the ANGF facility consists of two nominally rated 1,117 MW Westinghouse AP1000 nuclear power units built at a greenfield site; that is, a site with no existing nuclear generators already installed. The Facility configuration for the ANGF is the same as in the November 2016 Capital Cost Estimates for Utility Scale Electricity Generating Plants report, with the exception that the Facility is to be built at a greenfield site instead of a brownfield site (a site that already has operating nuclear units in place).
- **Onshore wind with Class I WTG (WNC1):** the WNC1 Facility is based on 34 WTGs, each with a rated capacity of 3 MW a hub height of 80 meters, and a rotor diameter of 95 meters. The total design capacity is 100 MW. The Facility configuration for the WNC1 Facility is the same as in the November 2016 Capital Cost Estimates for Utility Scale Electricity Generating Plants report, with the exception that the WNC1 Facility is to be built using International Electrotechnical Commission (IEC) Class I wind turbine generators, instead of the IEC Class II/III wind turbine generators used that report. IEC Class 1 turbines are designed to withstand higher average and extreme wind speeds, and different turbine ratings may be used to access different resources areas.
- **Battery storage (BES-2):** the BES-2 Facility is rated at 50.0 MW and 400 MWh. The Facility configuration for the BES-2 is the same as in the November 2016 Capital Cost Estimates for Utility Scale Electricity Generating Plants report, with the exception that the duration of discharge is rated for eight hours of operation instead of two hours. Energy storage devices may have somewhat different market applications, depending on their discharge duration capability.

As previously noted, costs are developed using a consistent methodology that includes a broad project scope and includes indirect and owners costs. The cost figures will not necessarily match those derived in other studies that employ different approaches to cost estimation.

Summary

The estimates provided by the consultant for this report are key inputs for EIA electric market projections, but they are not the sole driver of electric generation capacity expansion decisions. The evolution of the electricity mix in each of the 22 regions modeled in *AEO2017* is sensitive to many factors, including the projected evolution of capital costs over the modeling horizon, projected fuel costs, whether wholesale power markets are regulated or competitive, the existing generation mix, additional costs associated with environmental control requirements, and future electricity demand.

Users interested in further details regarding these additional cost estimates should review the consultant study prepared by Leidos Engineering, LLC in [Appendix C](#).

Table 1. Updated estimates of power plant capital and operating costs¹

	Plant Characteristics		Plant Costs (2016\$)			
	Nominal Capacity (MW)	Heat Rate (Btu/kWh)	Overnight Capital Cost (\$/kW)	Fixed O&M (\$/kW-yr)	Variable O&M (\$/MWh)	NEMS Input
Coal						
Ultra-Supercritical Coal with 90% CCS (USC/CCS90) ²	650	11,650	5,569	80.53	9.51	Y
Integrated Gasification Combined Cycle (IGCC)	618	8,600	4,908	65.4	5	N
Uranium						
Advanced Nuclear Greenfield Site (ANGF)	2,234	N/A	6,384	100.28	2.3	N
Wind						
Onshore Wind with Class I WTG (WNCI)	100	N/A	1,867	38	0	N
Storage						
Battery Storage (BES-2)	50	N/A	3,122	40	8	N

^[1] Leidos Engineering, LLC: "Review of Powerplant Performance and Cost Assumptions for NEMS: Technology Documentation Report-Addendum" January, 2017 (see attachment Appendix C).

Appendix C – Full Report

Appendix C – Full Report

**EOP III TASK 10388, SUBTASK 4 and TASK 10687,
SUBTASK 2.3.1 – REVIEW OF
POWER PLANT COST AND PERFORMANCE
ASSUMPTIONS FOR NEMS**

**Technology Documentation Report
ADDENDUM**

Prepared by:

LEIDOS ENGINEERING, LLC

Prepared For:

Energy Information Administration

Office of Electricity, Coal, Nuclear, and Renewables Analysis

Chris Namovicz

Jim Diefenderfer

January 2017

Disclaimer

Certain statements included in this report constitute forward-looking statements. The achievement of certain results or other expectations contained in such forward-looking statements involve known and unknown risks, uncertainties and other factors which may cause actual results, performance or achievements described in the report to be materially different from any future results, performance or achievements expressed or implied by such forward-looking statements. We do not plan to issue any updates or revisions to the forward-looking statements if or when our expectations or events, conditions, or circumstances on which such statements are based occur.

TABLE OF CONTENTS

1.	INTRODUCTION.....	1-1
1.1	Technologies Assessed.....	1-1
2.	GENERAL BASIS FOR TECHNOLOGY EVALUATION BASIS.....	2-1
2.1	Leidos Engineering, LLC Background	2-1
2.2	Base Fuel Characteristics	2-1
3.	ULTRA SUPERCRITICAL COAL WITH 90 PERCENT CCS (USC/CCS90).....	3-1
3.1	Mechanical Equipment and Systems.....	3-1
3.2	Electrical and Control Systems	3-2
3.3	Off-Site Requirements.....	3-2
3.4	Capital Cost Estimate	3-2
3.5	O&M Estimate	3-3
3.6	Environmental Compliance Information.....	3-4
4.	INTEGRATED GASIFICATION COMBINED CYCLE (IGCC)	4-1
4.1	Mechanical Equipment and Systems.....	4-1
4.2	Electrical and Control Systems	4-3
4.3	Off-Site Requirements.....	4-3
4.4	Capital Cost Estimate	4-4
4.5	O&M Estimate	4-5
4.6	Environmental Compliance Information.....	4-6
5.	ADVANCED NUCLEAR GREENFIELD SITE (ANGF)	5-1
5.1	Mechanical Equipment and Systems.....	5-1
5.2	Electrical and Control Systems	5-1
5.3	Off-Site Requirements.....	5-1
5.4	Capital Cost Estimate	5-1
5.5	O&M Estimate	5-3
5.6	Environmental Compliance Information.....	5-3
6.	ONSHORE WIND WITH CLASS I WTG (WNCI).....	6-1
6.1	Mechanical Equipment and Systems.....	6-1

6.2	Electrical and Control Systems	6-1
6.3	Off-Site Requirements.....	6-1
6.4	Capital Cost Estimate	6-2
6.5	O&M Estimate	6-2
6.6	Environmental Compliance Information.....	6-3
7.	BATTERY STORAGE 50 MW (BES-2)	7-1
7.1	Mechanical Equipment and Systems.....	7-1
7.2	Electrical and Control Systems	7-1
7.3	Off-Site Requirements.....	7-1
7.4	Capital Cost Estimate	7-1
7.5	O&M Estimate	7-2
7.6	Environmental Compliance Information.....	7-3

LIST OF FIGURES

FIGURE 3-1 – USC FACILITY DIAGRAM.....	3-1
FIGURE 3-2 – USC/CCS FACILITY DIAGRAM.....	3-2
FIGURE 4-1 – IGCC DESIGN CONFIGURATION.....	4-3
FIGURE 5-1 – AN DESIGN CONFIGURATION.....	5-1
FIGURE 6-1 – WNCI DESIGN CONFIGURATION.....	6-1
FIGURE 7-1 – BES-2 DESIGN CONFIGURATION.....	7-1

LIST OF TABLES

TABLE 1-1 – LIST OF TECHNOLOGIES FOR REVIEW	1-2
TABLE 2-1 – TECHNOLOGY PERFORMANCE SPECIFICATIONS	2-2
TABLE 3-1 – BASE PLANT SITE CAPITAL COST ESTIMATE FOR USC/CCS90.....	3-3
TABLE 3-3 – O&M EXPENSES FOR USC/CCS90 (650,000 KW NET)	3-4
TABLE 3-4 – ENVIRONMENTAL EMISSIONS FOR USC/CCS90	3-4
TABLE 4-1 – BASE PLANT SITE CAPITAL COST ESTIMATE FOR IGCC.....	4-4
TABLE 4-3 – O&M EXPENSES FOR IGCC (618,000 KW).....	4-5
TABLE 4-4 – ENVIRONMENTAL EMISSIONS FOR IGCC	4-6
TABLE 5-1 – BASE PLANT SITE CAPITAL COST ESTIMATE FOR ANGF.....	5-2
TABLE 5-3 – O&M EXPENSES FOR ANGF.....	5-3
TABLE 5-4 – ENVIRONMENTAL EMISSIONS FOR ANGF	5-3
TABLE 6-1 – WTG COMPARISION BETWEEN CLASS II/III AND CLASS I	6-1
TABLE 6-2 – LOCATION-BASED COSTS FOR WNCI	6-2
TABLE 6-3 – O&M EXPENSES FOR WNCI.....	6-3
TABLE 6-4 – ENVIRONMENTAL EMISSIONS FOR WNCI	6-3
TABLE 7-1 – LOCATION-BASED COSTS FOR BES-2.....	7-2
TABLE 7-3 – O&M EXPENSES FOR BES-2	7-3
TABLE 7-4 – ENVIRONMENTAL EMISSIONS FOR BES-2.....	7-3
TABLE 3-2 – LOCATION-BASED COSTS FOR USC/CCS90 (650,000 KW).....	A-1
TABLE 4-2 – LOCATION-BASED COSTS FOR IGCC FACILITY (618,000 KW).....	A-3
TABLE 5-2 – LOCATION-BASED COSTS FOR ANGF FACILITY (2,234,000 KW)....	A-5
TABLE 6-2 – LOCATION-BASED COSTS FOR WNCI FACILITY (100,000 KW).....	A-7
TABLE 7-2 – LOCATION-BASED COSTS FOR BES-2 FACILITY (50,000 KW)	A-9

LIST OF ACRONYMS AND ABBREVIATIONS

(Below is a list of Acronyms and Abbreviations used in addition to the Submitted EIA April 2016 Report.)

ANGF	Advanced Nuclear Greenfield Site
BES-2	Battery Storage at 50 MW
IGCC	Integrated Gasification Combined Cycle
USC/CCS90	Ultra Supercritical Coal with CCS at 90 Percent
WNC1	Onshore Wind with Class I turbines

THIS PAGE INTENTIONALLY BLANK

1. INTRODUCTION

This Addendum to the report, “*EOP III Task 10688, Subtask 4 and Task 10687 Subtask 2.3.1-Review of Power Plant Cost and Performance Assumptions for NEMS*,” submitted April 2016 (the “Submitted EIA April Report”), presents Leidos’ performance and cost assessment of five additional power generation technologies utilized by the EIA in the EMM of the NEMS. The assessment for each of the technologies considered includes the following:

- Overnight construction costs, construction lead times, first year of commercial application, typical unit size, contingencies, fixed and variable operating costs, and efficiency (heat rate). The analysis was conducted to ensure that the overnight cost estimates developed for use in the EMM for electric generating technologies are consistent in scope, accounting for generally all costs in the planning and development of a power plant including the basic interconnection to the grid at the plant site and other utility interconnections, but excluding financing costs.
- For emission control technologies, the removal rates for pollutants and other assumptions were examined.
- Review of the regional multipliers that are used to represent local conditions, such as labor rates that are included in EMM.
- Review of the appropriateness of technology-specific project and process contingency assumptions (capturing differences between engineering estimates and realized costs for new technologies).
- Where possible, compare the values used by EIA with those for recently built facilities in the U.S. or abroad. Where such actual cost estimates do not exist, an assessment was made between values used by EIA and other analyst estimates, as well as vendor estimates.
- The key factors expected to drive each technology’s costs.
- Documentation of the source and basis for final recommendations for altering or retaining the various assumptions.

1.1 TECHNOLOGIES ASSESSED

Table 1-1 lists all technologies to be assessed in this project.

TABLE 1-1 – LIST OF TECHNOLOGIES FOR REVIEW

TECHNOLOGY	DESCRIPTION	COMMENTS
Coal with 90% CO ₂ removal	650,000 kW Ultra Supercritical with 90 percent Carbon Capture and Sequestration	
IGCC	618,000 kW Integrated Gasification Combined Cycle Plant	
Nuclear Greenfield	2,234,000 kW Nuclear plant built at a Greenfield location	
Wind	100,000 kW Onshore Wind Energy Plant with Class I Wind Turbines	
Battery	50,000 kW Battery Storage Plant with 8 hour battery duration	

2. GENERAL BASIS FOR TECHNOLOGY EVALUATION BASIS

This section specifies the general evaluation basis used for all technologies reviewed herein.

2.1 LEIDOS ENGINEERING, LLC BACKGROUND

Leidos is a technical solutions and infrastructure consulting firm that has provided technical and business consulting in the energy industry since 1942. Particularly, Leidos has supported the purchase, sale, financing, and Owner's advisory consulting for tens-of-billions of dollars of power plants across the world in all commercial power generating technologies as well as many emerging technologies. This background has supported Leidos' acumen with respect to construction costs, operating costs, technology development and evolution, as well as trends in environmental regulation and compliance.

2.2 BASE FUEL CHARACTERISTICS

This section provides a general fuel basis for each of the fuel types utilized by the technologies considered in this report, which was listed in Table 1-1. Each of the technologies that combust a fuel has the ability to operate over a range of fuels; these fuels are outlined in Section 2 of the submitted EIA April 2016 Report. Table 2-1 provides the technology performance for each technology.

TABLE 2-1 – TECHNOLOGY PERFORMANCE SPECIFICATIONS

Technology	Fuel	Net Nominal Capacity (kW) ⁽¹⁾	Net Nominal Heat Rate (Btu/kWh) ⁽²⁾	Capital Cost (\$/kW) ⁽³⁾	Fixed O&M (\$/kW-yr) ⁽⁴⁾	Variable O&M (\$/MWh) ⁽⁵⁾	SO₂ (lb/MMBtu) ⁽⁶⁾	NO_x (lb/MMBtu)	CO₂ (lb/MMBtu)
Ultra Supercritical Coal with CCS (USC/CCS)	Coal	650,000	11,650	5,569	80.53	9.51	0.02 ⁽⁷⁾	0.06	20.6 ⁽⁸⁾
IGCC	Syngas	618,000	8,600	4,908	65.40	5.00	0.0095 ⁽⁹⁾	0.013 ⁽¹⁰⁾	206
Advanced Nuclear (AN)	Uranium	2,234,000	N/A	6,384	100.28	2.30	0	0	0
Onshore Wind (WN)	Wind	100,000	N/A	1,867	39.70	0	0	0	0
Battery Storage (BES)	Lithium Ion	50,000	N/A	3,122	40.00	8.00	N/A	N/A	N/A

- (1) Capacity is net output basis and includes auxiliary loads.
- (2) Heat Rate is on a net HHV basis for British thermal units per kilowatt-hour (“Btu/kWh”) at ISO conditions.
- (3) Capital Cost excludes financing-related costs (e.g., fees, interest during construction).
- (4) FOM expenses exclude owner’s costs (e.g., insurance, property taxes, and asset management fees).
- (5) VOM expenses include major maintenance but not fuel-related expenses.
- (6) Million Btu (“MMBtu”).
- (7) Assuming 3 percent sulfur coal at 12,000 British thermal units per pound (“Btu/lb”) and a 99.5 percent sulfur removal rate.
- (8) Assuming 90 percent capture.
- (9) Assuming 3.9 percent sulfur coal at 11,000 British thermal units per pound (“Btu/lb”) and a 99.5 percent sulfur removal rate.
- (10) Assuming 2.5 parts per million volume dry (“ppmvd”) corrected to 15 percent O₂ f or F-Class engine.

3. ULTRA SUPERCRITICAL COAL WITH 90 PERCENT CCS (USC/CCS90)

3.1 MECHANICAL EQUIPMENT AND SYSTEMS

The plant configuration for the USC with 90 Percent CCS Facility (“USC/CCS90”), is the same as Section 3 of the Submitted EIA April Report, with two exceptions: (1) an amine scrubbing system, utilizing MEA as a solvent, to capture CO₂ from the flue gas, and (2) the scaling of the boiler to a larger size, as described below. The assumed carbon capture was set at 90 percent. The captured CO₂ is compressed to approximately 2,000 psia for injection into a pipeline at the plant fence line as a supercritical fluid. The net output of the USC/CCS90 Facility case is 650 MW, and since based on Leidos’ calculations the CCS system requires about 30 percent of the given facility’s gross capacity in auxiliary load, the USC/CCS90 Facility assumes that the boiler is increased by approximately 30 percent (i.e., it is approximately 130 percent the size of the boiler in the USC Facility), which provides the necessary steam to facilitate the capture process and to run a steam-driven compressor for compressing the CO₂ for sequestration. Leidos used 931 MW gross output to obtain the 650 MW net output. Figure 3-1 presents a diagram of the USC and Figure 3-2 presents a diagram of the USC/CCS90 Facility.

FIGURE 3-1 – USC FACILITY DIAGRAM

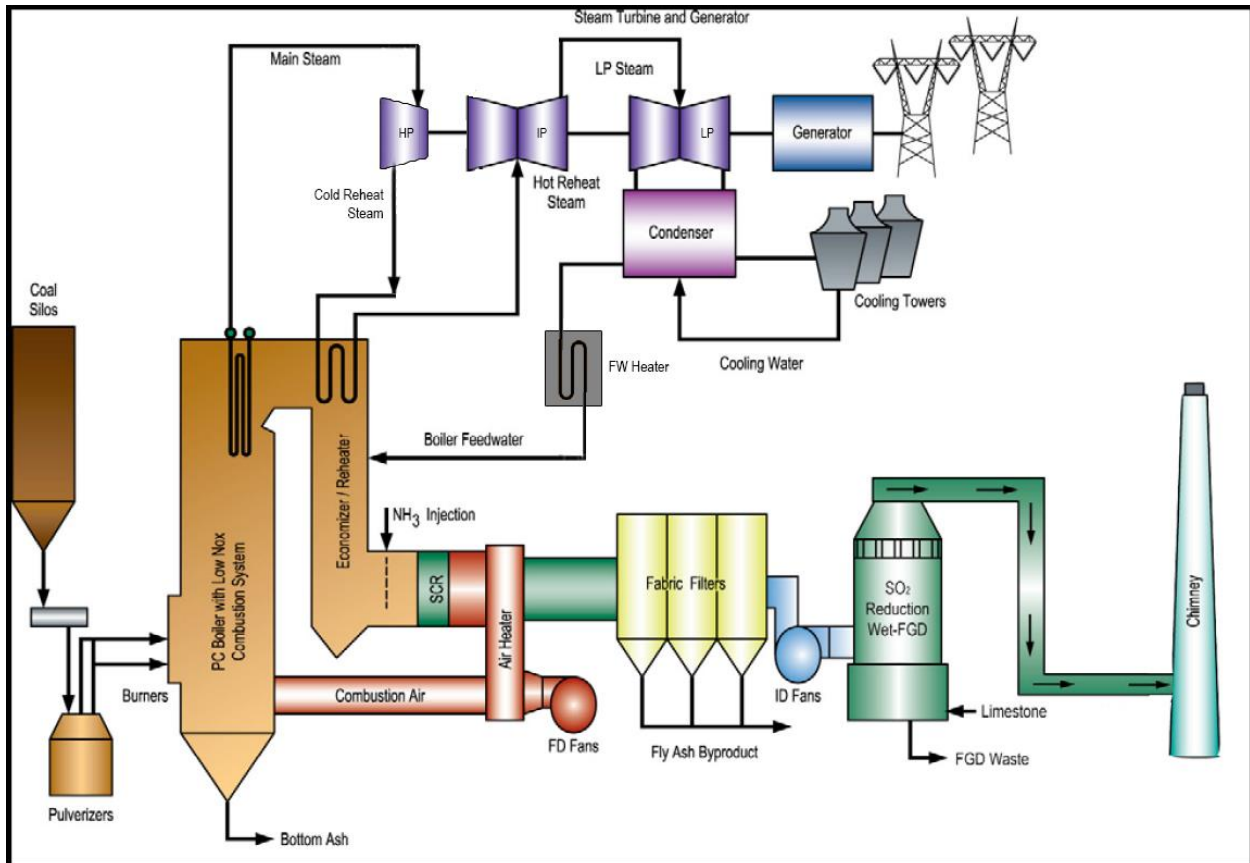
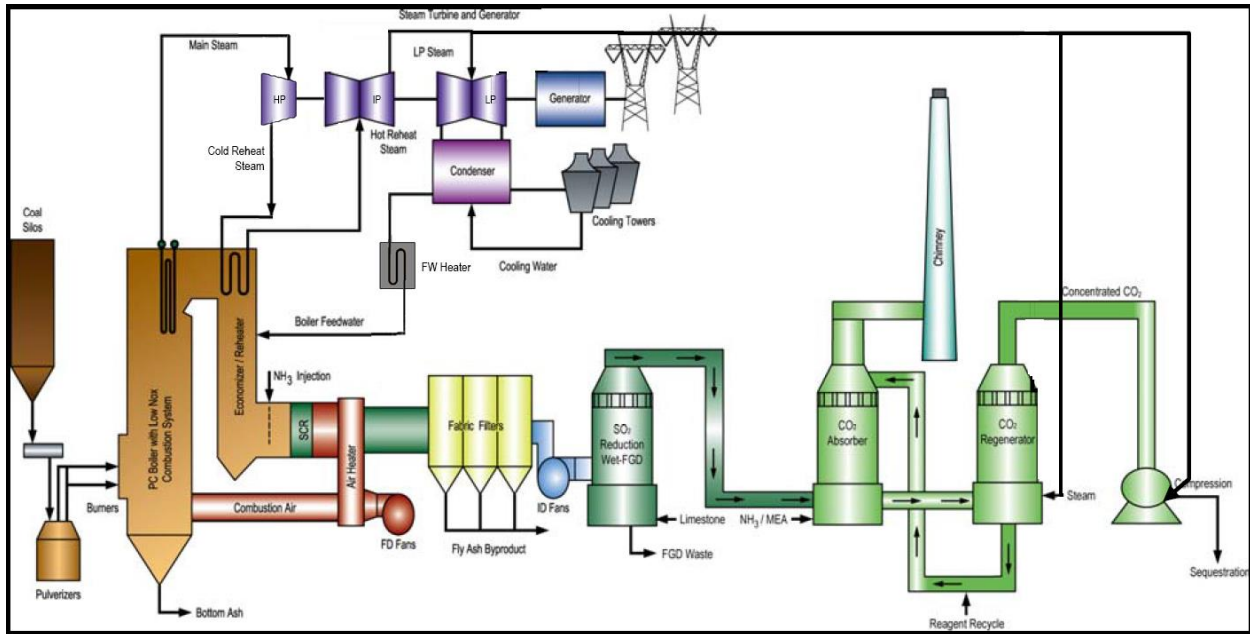

FIGURE 3-2 – USC/CCS FACILITY DIAGRAM



3.2 ELECTRICAL AND CONTROL SYSTEMS

The electrical and control systems for the USC/CCS90 Facility are materially similar to the USC Facility in the Submitted EIA April Report.

3.3 OFF-SITE REQUIREMENTS

The off-site requirements for the USC/CCS90 Facility are materially similar to the USC Facility in the Submitted EIA April Report, except that the CO₂ needs sequestering in one of the following geologic formations: (1) exhausted gas storage location, (2) unmineable coal seam, (3) enhanced oil recovery, or (4) saline aquifer. To the extent that a sequestration site is not near the given facility being analyzed, transportation for a viable sequestration site has the potential to materially affect the capital cost estimates discussed below.

3.4 CAPITAL COST ESTIMATE

The base Cost Estimate for the USC/CCS90 Facility with a nominal capacity of 650 MW is \$5,569/kW. The capital cost estimate was based on the USC Facility (without CCS) in the Submitted EIA April Report and the base Cost Estimate was increased to include the expected costs of CCS at 90 percent. Since there are limited full-scale pulverized coal facilities operating with CCS in the world, our estimate is based on industry research. Our team tested the veracity of this research against assumptions for implementing the additional equipment necessary to effectuate CCS on an advanced coal facility. Table 3-1 summarizes the Cost Estimate categories for the USC/CCS Facility.

TABLE 3-1 – BASE PLANT SITE CAPITAL COST ESTIMATE FOR USC/CCS90

TECHNOLOGY: USC/CCS90		
Nominal Capacity (ISO): 650,000 kW Net Output		
Nominal Heat Rate (ISO): 11,650 Btu/kWh-HHV Net		
Capital Cost Category	(000s) (August 19, 2016\$)	
Civil Structural Material and Installation		328,347
Mechanical Equipment Supply and Installation		1,548,824
Electrical / I&C Supply and Installation		235,801
Project Indirects ⁽¹⁾		601,931
EPC Cost before Contingency and Fee		2,714,903
Fee and Contingency		301,389
Total Project EPC ⁽²⁾		3,016,292
Owner Costs (excluding project finance) ⁽²⁾		603,258
Total Project Cost (excluding finance)		3,619,550
Total Project EPC	/ kW	4,640
Owner Costs 20% (excluding project finance)	/ kW	928
Total Project Cost (excluding project finance)	/ kW	5,569
<small>(11) Includes engineering, distributable costs, scaffolding, construction management, and start-up. (12) EPC costs include Sequestration to Plant Fence, Owners cost may not bear all pipeline costs required past the demarcation point.</small>		

The locational adjustments for the USC/CCS90 Facility are similar to those made for the USC Facility in the Submitted EIA April Report.

Table 3-2 in the Appendix shows the USC/CCS90 Facility capital cost variations for alternative U.S. plant locations, including the difference between the given location and the average location specified for the Cost Estimate.

3.5 O&M ESTIMATE

The O&M items for the USC/CCS90 Facility are the same as those discussed in Section 3.5 of the Submitted EIA April Report for the USC Facility (without CCS), except that adders are included to both FOM and VOM to accommodate the expenses associated with compressor maintenance, sequestration maintenance, and the associated additional labor required to manage, operate, and

maintain the additional equipment. Table 3-3 presents the FOM and VOM expenses for the USC/CCS Facility.

TABLE 3-3 – O&M EXPENSES FOR USC/CCS90 (650,000 KW NET)

TECHNOLOGY:	USC/CCS90
Fixed O&M Expense	\$80.53/kW-year
Variable O&M Expense	\$9.51/MWh

3.6 ENVIRONMENTAL COMPLIANCE INFORMATION

In addition to the equipment utilized for environmental compliance in the Submitted EIA April Report for the USC Facility, the USC/CCS90 Facility includes an amine scrubber that is intended to remove 90 percent of the CO₂ produced in the combustion process, wherein the captured CO₂ is later compressed to HP and sequestered, as discussed above. Increased amount of SO₂ scrubbing is required to avoid contamination of the MEA. Such costs for increased scrubbing are included. Table 3-4 presents the environmental emissions for the USC/CCS90 Facility.

TABLE 3-4 – ENVIRONMENTAL EMISSIONS FOR USC/CCS90

TECHNOLOGY:	USC/CCS90
NO_x	0.06 lb/MMBtu
SO₂	0.02 lb/MMBtu
CO₂	20.6 lb/MMBtu

4. INTEGRATED GASIFICATION COMBINED CYCLE (IGCC)

4.1 MECHANICAL EQUIPMENT AND SYSTEMS

The following describes the IGCC Facility, which is a nominal 618 MW net coal-fired gasification-to-power facility. The feed for the gasification system is a slurry of water and ground coal and/or petroleum coke. The raw feedstock is ground in rod mills along with recycled water and slag fines to form the slurry. A fluxing agent is also added, if necessary, depending on the properties of the feedstock, to facilitate slagging at appropriate temperatures in the gasifier.

ASU provide a 95 percent pure O₂ stream for gasification, and nitrogen for use as a diluent in the CTs, and for purging the gasifiers.

The IGCC Facility is based on two trains of the gasifier, which is a two-stage, refractory lined vessel that converts the slurry feed into syngas consisting of hydrogen, CO, CO₂, methane, nitrogen, argon and water along with sulfur compounds in the form of H₂S and COS and a small amount of NH₃. The first stage is the slagging section in which the feedstock is partially combusted with O₂ at elevated temperature and pressure (2,500 °F and 540 psia). O₂ and preheated slurry are fed to each of two opposing mixing nozzles at opposite ends of the horizontal section. The gasification temperature is maintained above the ash fusion point to allow for slag formation and carbon conversion.

The raw syngas from the first stage flows into the vertical second stage where additional feed slurry is introduced to take advantage of the sensible heat in the gas. This fuel undergoes devolatilization and pyrolysis generating additional syngas. The endothermic nature of the reactions and the introduction of a quench fluid reduce the temperature of the gas exiting to the gasifier to approximately 1,900°F. At these temperatures (2,500°F to 1,900°F), two additional reactions occur, which change the character of the syngas as follows: (1) carbon-steam to produce CO; and (2) water gas shift (steam and CO) to produce hydrogen and CO₂. In addition, the lower reaction temperature in the second stage allows the formation of methane. Unreacted char is carried overhead and exits the reactor with the syngas. This char is recycled to the first stage of gasification.

The mineral matter in the feedstock and any fluxing agent form a molten slag that flows out of the horizontal section into water quench bath. The cooled slag exits the bottom of the quench, is crushed and exits the unit through a continuous slag removal system as a slurry.

The hot raw syngas is cooled in a vertical fire tube boiler from 1,900°F to 700°F. The hot gas is on the tube side with pressurized water on the shell side. This unit generates HP saturated steam. The saturated steam is sent to the HRSGs in the power block.

After cooling, the syngas is cleaned of entrained particles in a filter vessel containing numerous candlestick-type filter elements. The particles collect on the filter elements producing an essentially particulate matter free syngas that proceeds through the system.

Captured particulate matter is cleaned from the filter elements using cleaned syngas (in a back-pulse mode) and the carbon-rich material is pneumatically conveyed back to the first stage of the gasifier for conversion.

Following particulate matter removal, the syngas is scrubbed with water to remove chlorine and trace metals. The scrubbing medium is condensed sour water from the low-temperature heat recovery system.

After the chlorine scrubber, the raw syngas is treated in COS hydrolysis units, which convert the COS in the syngas to H₂S. The syngas is then cooled to approximately 100°F in a series of shell and tube heat exchangers in a step known as low-temperature heat recovery. This cooling removes most of the water in the syngas. In addition, most of the NH₃ and a small portion of CO₂ and H₂S are absorbed in the water. A portion of the condensed water is used in the chlorine scrubber with the remainder sent to sour water treatment. The low temperature heat removed prior to AGR is used within the process.

After low-temperature heat recovery, the syngas passes through a mercury removal system consisting of sulfated activated carbon beds, followed by H₂S removal in the AGR units. The AGR units use the Selexol solvent in a single absorption stage to remove over 99 percent of the sulfur from the syngas. Finally, the treated syngas is moisturized and sent to the power block.

The acid gas streams containing H₂S and COS with some CO₂ from AGR and sour water treatment are fed to the SRU. The SRUs are based on a standard Claus process to convert the acid gas to pure molten sulfur; the sulfur is a byproduct that potentially could be sold. The tail gas from the SRUs, composed of CO₂, nitrogen, and small amounts of sulfur, is catalytically hydrogenated to convert all of the sulfur to H₂S. This converted tail gas is compressed and recycled to the gasifiers.

Process water blowdown and water condensed during cooling of the sour syngas contains small amounts of dissolved gases (H₂S, CO₂ and NH₃). This water is treated in sour water stripping units and either recycled to slurry preparation or further treated in a ZLD system to recover and reuse water. Solid waste from the ZLD is landfilled.

The power block for the IGCC Facility case is based on a two-on-one combined-cycle configuration using F-class CTs, each with a nominal output of 232 MW. The STG gross output is 279 MW, and auxiliary power consumption is approximately 125 MW. The combined cycle is similar to Section 8 of the Submitted EIA April Report for the NGCC Facility, except the CTs are designed to combust natural gas and/or syngas, and the combustors are not DLN. Figure 4-1 presents the IGCC process flow diagram.

FIGURE 4-1 – IGCC DESIGN CONFIGURATION

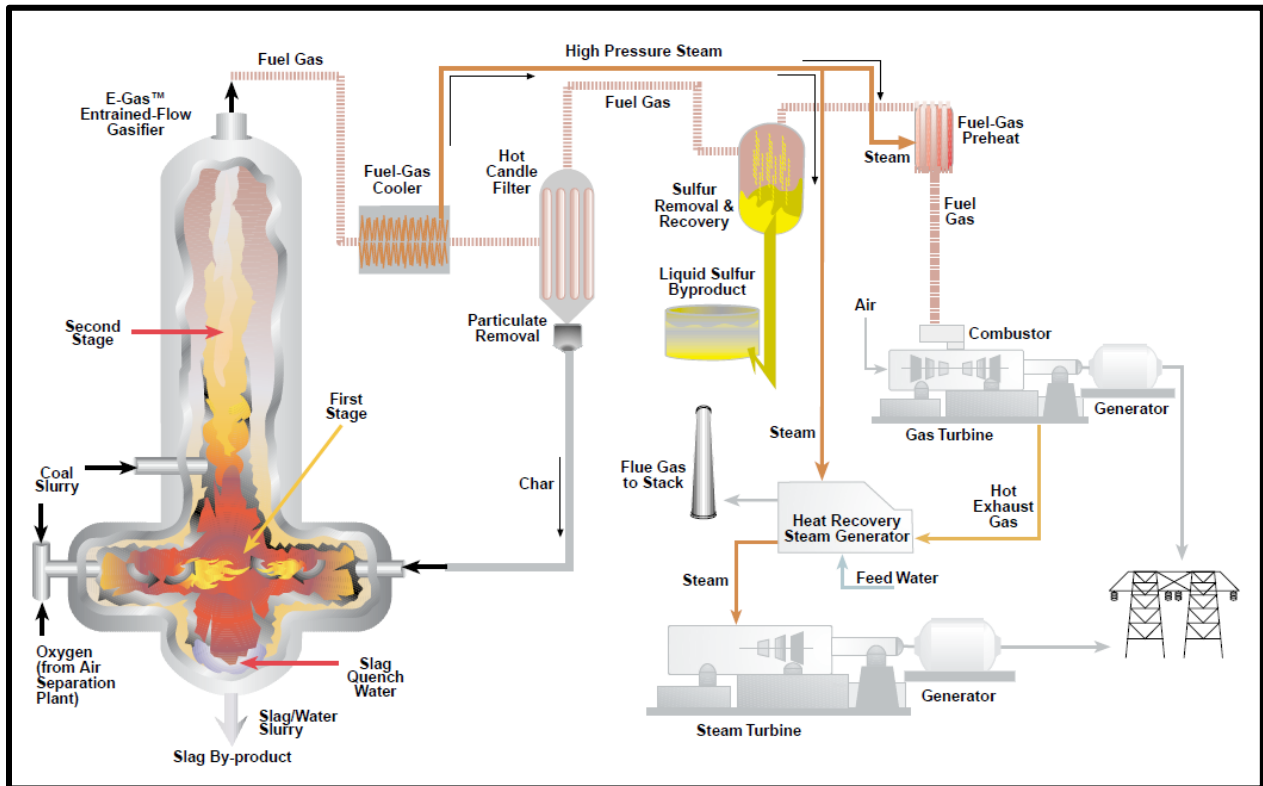

Source: NETL

4.2 ELECTRICAL AND CONTROL SYSTEMS

The IGCC Facility has two CT electric generators and one ST electric generator. The generators for the CTs are 60 Hz machines rated at approximately 258 MVA with an output voltage of 18 kV. The ST electric generator is a 60 Hz machine rated at approximately 310 MVA with an output voltage of 18 kV. Each CT electric generator is connected to a high-voltage bus in the IGCC Facility switchyard via a dedicated generator circuit breaker, GSU, and a disconnect switch. The ST electric generator is connected directly to its GSU and connected through a disconnect switch between two breakers on the high-voltage bus. The GSUs increase the voltage from the electric generators from 18 kV to interconnected transmission system high voltage.

The IGCC Facility is controlled using a DCS. The DCS provides centralized control of the facility by integrating the control systems provided with each individual CT and associated electric generator, ST and associated electric generator, and the control of BOP systems and equipment.

4.3 OFF-SITE REQUIREMENTS

Coal is delivered to the IGCC Facility by rail, truck or barge. Water for all processes at the IGCC is obtained from one of several available water sources; however, water is typically sourced from an adjacent river, when possible. The IGCC uses a water treatment system and a high-efficiency reverse osmosis system to reduce the dissolved solids from the cooling water and to provide distilled water for HRSG makeup. Wastewater is sent to an adjacent river or other approved wastewater delivery point. Further, the electrical interconnection from the IGCC on-site switchyard is effectuated by a connection to an adjacent utility substation.

4.4 CAPITAL COST ESTIMATE

The base Cost Estimate for the IGCC Facility with a net nominal capacity of 618 MW is \$4,908 /kW Table 4-1 summarizes the Cost Estimate categories for the IGCC Facility.

TABLE 4-1 – BASE PLANT SITE CAPITAL COST ESTIMATE FOR IGCC

TECHNOLOGY: IGCC		
NOMINAL CAPACITY (ISO): 618,000 kW		
NOMINAL HEAT RATE (ISO): 8,600 Btu/kWh-HHV		
<u>Capital Cost Category</u>		<u>(000s) (August 19, 2016\$)</u>
Civil Structural Material and Installation		124,918
Mechanical Equipment Supply and Installation		1,433,721
Electrical / I&C Supply and Installation		269,798
Project Indirects ⁽¹⁾		428,356
EPC Cost before Contingency and Fee		2,256,793
Fee and Contingency		270,815
Total Project EPC		2,527,608
Owner Costs (excluding project finance)		505,522
Total Project Cost (excluding finance)		3,033,130
Total Project EPC	/ kW	4,090
Owner Costs 20% (excluding project finance)	/ kW	818
Total Project Cost (excluding project finance)	/ kW	4,908

(1) Includes engineering, distributable costs, scaffolding, construction management, and start-up.

For this type of technology and power plant configuration, our regional adjustments took into consideration the following: outdoor installation considerations, seismic design differences, remote location issues, labor wage and productivity differences, location adjustments, owner cost differences, and the increase in overheads associated with these six adjustments.

Outdoor installation locations are considered in geographic areas where enclosed structures for the boilers would not be required due to the low probability of freezing. The locations that included outdoor installation are Alabama, Arizona, Arkansas, Florida, Georgia, Louisiana, Mississippi, New Mexico, and South Carolina.

Seismic design differences among the various locations were based on U.S. seismic map information that detailed the various seismic zones throughout the U.S. No cost increases were associated with seismic Zone 0 and cost step increases were considered for Zones 1, 2, 3 and 4.

Remote locations issues are related to geographic areas that typically require installation of man camps, higher craft incentives, and higher per diems for construction, because such areas are long distances from urban areas, where labor is generally abundant. Remote location designations were also considered in locations where higher equipment freight costs are typically incurred, which for example are regions not near established rail or highway access. Remote locations related to the IGCC Facility include; Fairbanks, Alaska; Albuquerque, New Mexico; and Cheyenne, Wyoming.

Labor wage and productivity differences were handled as discussed in Section 2.5.1 of the Submitted EIA April Report, taking into consideration the amount of labor we estimated for the IGCC Facility.

Location adjustments were made to locations where higher cost of living levels are incurred and/or where population density generally correlates to higher construction costs for power and other infrastructure projects. These locations include, but are not limited to, Alaska, California, Connecticut, Delaware, District of Columbia, Illinois, Indiana, Maine, Maryland, Massachusetts, Minnesota, New York, Ohio, Oregon, Virginia, Washington, Wisconsin, and Wyoming.

Owner costs were reviewed based on the need for utility upgrades and/or infrastructure costs such as new facility transmission lines to tie to existing utility transmission substations or existing transmission lines.

Table 4-2 in the Appendix present the IGCC Facility capital cost variations for alternative U.S. plant locations.

4.5 O&M ESTIMATE

In addition to the general O&M items discussed in Section 2.6.2 of the Submitted EIA April Report, the IGCC Facility includes the major maintenance for the CTs, as well as the BOP, including the ST, associated electric generators, HRSGs, and emissions reduction catalysts. Additionally, provisions need to be made for routine and major maintenance for the gasification systems, the ASU, and associated gasification auxiliary equipment needs to be made and are included in the Fixed O&M expenses. For example, major maintenance for the gasifier includes repair and replacement of the refractory. Typically, significant overhauls on an IGCC Facility occur no less frequently than 18 months and the cycle for the power generation equipment is similar to the to the NGCC Facility in Section 8 of the Submitted EIA April Report. Table 4-3 presents the O&M expenses for the IGCC Facility.

TABLE 4-3 – O&M EXPENSES FOR IGCC (618,000 KW)

TECHNOLOGY:	IGCC
Fixed O&M Expense	\$65.40 /kW-year
Variable O&M Expense	\$5.00 /MWh

4.6 ENVIRONMENTAL COMPLIANCE INFORMATION

The IGCC uses syngas combustors (which do not have DLN) in the CTs to manage the production of NO_x. Control of NO_x is accomplished through dilution of the syngas fuel with nitrogen and/or moisture, and an SCR in the HRSG. SO₂ in the IGCC is managed through the removal of sulfur in the syngas via the Selexol AGR system prior to combustion. The IGCC does not include any control devices for CO₂, which is proportional to the heat rate (inversely proportional to the efficiency) of the technology. However by using Selexol AGR, the configuration can be modified to capture CO₂ at a later time. Water, wastewater, and solid waste compliance are achieved through traditional on-site and off-site methods, and the costs for such compliance are included in the O&M Estimate for the IGCC. Table 4-4 presents environmental emissions for the IGCC Facility.

TABLE 4-4 – ENVIRONMENTAL EMISSIONS FOR IGCC

TECHNOLOGY:	IGCC
NO _x	0.0095 lb/MMBtu
SO ₂	0.013 lb/MMBtu
CO ₂	206 lb/MMBtu

5. ADVANCED NUCLEAR GREENFIELD SITE (ANGF)

5.1 MECHANICAL EQUIPMENT AND SYSTEMS

The Advanced Nuclear Greenfield Site (“ANGF”) Facility consists of two nominally rated 1,117 MW Westinghouse AP1000 nuclear power units built at a greenfield site.

The Facility configuration for the ANGF is the same as Section 12 of the Submitted EIA April Report, with the exception that the Facility is to be built at a greenfield site instead of a brownfield site. Figure 5-1 presents a simplified process flow diagram for the ANGF Facility.

FIGURE 5-1 – AN DESIGN CONFIGURATION

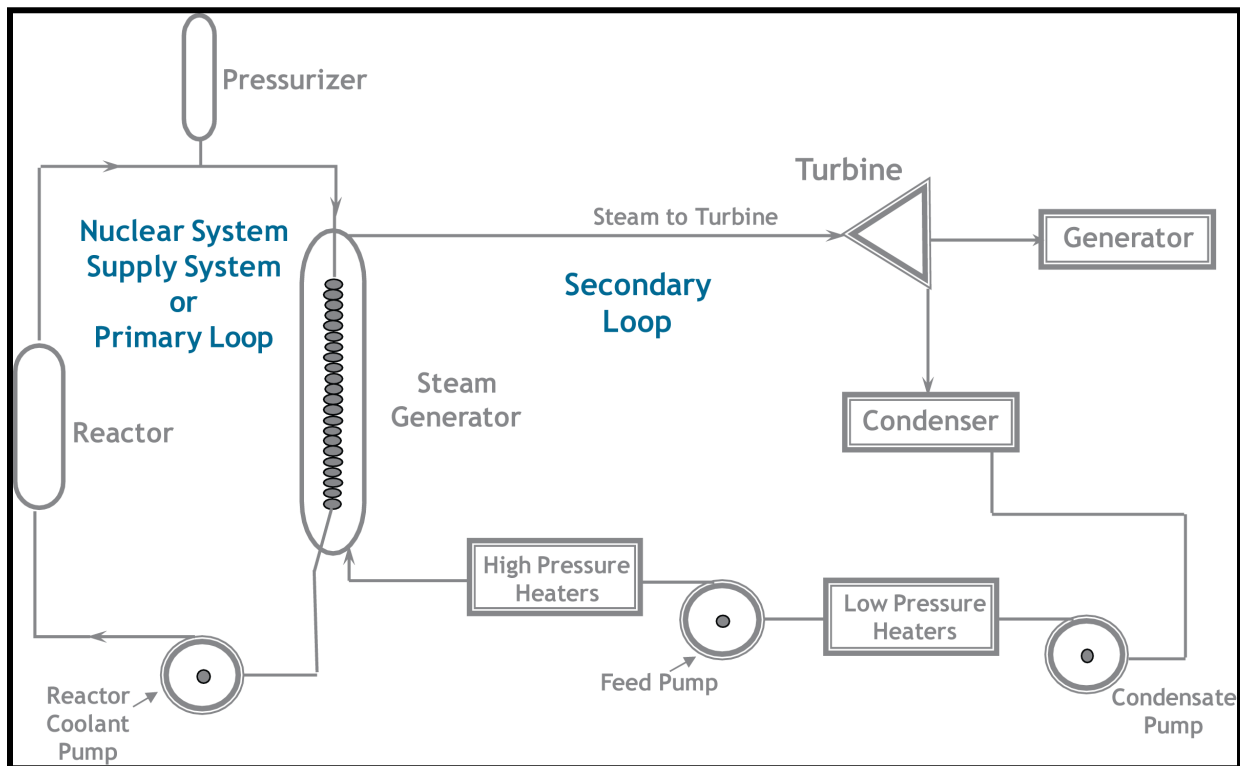

5.2 ELECTRICAL AND CONTROL SYSTEMS

The electrical and control systems for the ANGF Facility are materially similar to the AN Facility in the Submitted EIA April Report.

5.3 OFF-SITE REQUIREMENTS

The off-site requirements for the ANGF Facility are materially similar to the AN Facility in the Submitted EIA April Report.

5.4 CAPITAL COST ESTIMATE

The base Cost Estimate for the ANGF Facility with a nominal capacity of 2,234 MW is \$6,384/kW. Table 5-1 summarizes the Cost Estimate categories for the ANGF Facility.

TABLE 5-1 – BASE PLANT SITE CAPITAL COST ESTIMATE FOR ANGF

TECHNOLOGY: ANGF		
NOMINAL CAPACITY (ISO): 2,234,000 kW		
NOMINAL HEAT RATE (ISO): N/A Btu/kWh-HHV		
<u>Capital Cost Category</u>		<u>(000s) (August 19, 2016\$)</u>
Civil Structural Material and Installation		1,927,067
Mechanical Equipment Supply and Installation		3,782,925
Electrical / I&C Supply and Installation		700,954
Project Indirects ⁽¹⁾		3,029,122
EPC Cost before Contingency and Fee		9,440,067
Fee and Contingency		1,446,413
Total Project EPC		10,886,479
Owner Costs (excluding project finance)		3,374,809
Total Project Cost (excluding finance)		14,261,289
Total Project EPC	/ kW	4,873
Owner Costs 29% (excluding project finance)	/ kW	1,511
Total Project Cost (excluding project finance)	/ kW	6,384

(1) Includes engineering, distributable costs, scaffolding, construction management, and start-up.

The ANGF Cost Estimate is assumed to be identical to the Cost Estimate from the AN Cost Estimate in the Submitted EIA April Report, with the exception that we believe there is to be an increase to the Owners Cost for the ANGF Facility. The increase includes: generation tie lines, licensing increases for NRC COLA and CPCN, initial fuel load, training and information requirements, property taxes, land costs, development fees, work capital, and other infrastructure costs. In addition to the increased costs identified, the Owner should also expect an increase to the Owner-specific costs for project management, construction management, quality assurance and quality control, engineering, project controls, environmental health and safety, and start-up costs. We estimate that an increase to only the Owners Costs of approximately 40 percent is sufficient to cover the additions outlined above.

The locational adjustments for the ANGF Facility are similar to those made for the AN Facility in the Submitted EIA April Report.

Table 5-2 in the Appendix presents the ANGF Facility capital cost variations for alternative U.S. plant locations, including the difference between the given location and the average location specified for the Cost Estimate.

5.5 O&M ESTIMATE

The O&M items for the ANGF Facility are the same as those discussed in Section 12 of the Submitted EIA April Report for the AN Facility. Table 5-3 presents the FOM and VOM expenses for the ANGF Facility.

TABLE 5-3 – O&M EXPENSES FOR ANGF

TECHNOLOGY:	ANGF
Fixed O&M Expense	\$100.28/kW-year
Variable O&M Expense	\$2.30/MWh

5.6 ENVIRONMENTAL COMPLIANCE INFORMATION

Environmental compliance with respect to air emissions is effectively not necessary for the ANGF Facility, as this technology does not combust a fuel as is the case for other non-renewable power technologies. While there are environmental compliance considerations for a given nuclear facility (e.g., spent nuclear fuel), only air emissions were considered in this report. Table 5-4 presents environmental emissions for the ANGF Facility.

TABLE 5-4 – ENVIRONMENTAL EMISSIONS FOR ANGF

TECHNOLOGY:	ANGF
NO _x	0 lb/MMBtu
SO ₂	0 lb/MMBtu
CO ₂	0 lb/MMBtu

THIS PAGE INTENTIONALLY BLANK

6. ONSHORE WIND WITH CLASS I WTG (WNCI)

6.1 MECHANICAL EQUIPMENT AND SYSTEMS

The Onshore Wind with a Class I WTG (“WNCI”) Facility is based on 34 WTGs, each with a rated capacity of 3 MW, a hub height of 80 meters, and a rotor diameter of 95 meters. The total design capacity is 100 MW. The Facility configuration for the WNCI Facility is the same as Section 14 of the Submitted EIA April Report, with the exception that the WNCI Facility is to be built using Class I WTGs, instead of the Class II/III used in Section 14 of the Submitted EIA April Report. The key characteristic differences between the assumed WTG configurations are summarized in Table 6-1. Figure 6-1 presents a simplified process flow diagram for the WNCI Facility.

TABLE 6-1 – WTG COMPARISON BETWEEN CLASS II/III AND CLASS I

WTG CHARACTERISTICS	CLASS II/III	CLASS I
Generator Rating (MW) ⁽¹⁾	1.79	3.0
Rotor Diameter (m) ⁽²⁾	100	95
Hub Height (m)	80	80

(1) Megawatt (MW).
 (2) Meter (m).

FIGURE 6-1 – WNCI DESIGN CONFIGURATION

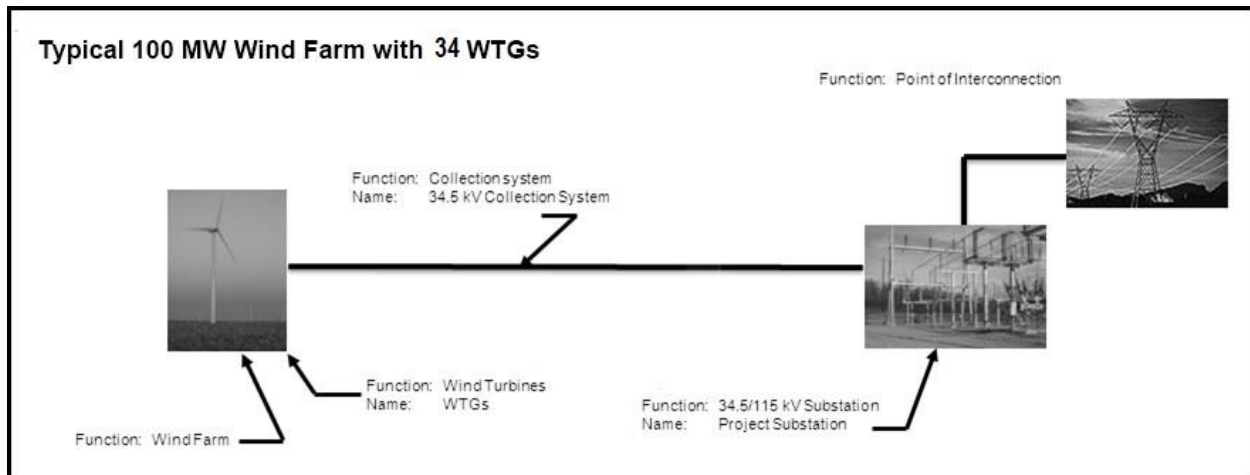

6.2 ELECTRICAL AND CONTROL SYSTEMS

The electrical and control systems for the WNCI Facility is materially similar to the WN Facility in the Submitted EIA April Report, with the exception that the WNCI Facility is to use 34 WTGs at 3 MW each, and that step-up voltage to 34.5 kV can be completed either in the Nacelle, or with a pad-mounted transformer.

6.3 OFF-SITE REQUIREMENTS

The off-site requirements for the WNCI Facility are materially similar to the WN Facility in the Submitted EIA April Report.

6.4 CAPITAL COST ESTIMATE

The base Cost Estimate for the WNCI Facility with a nominal capacity of 100 MW is \$1,867/kW. Table 6-2 summarizes the Cost Estimate categories for the WNCI Facility.

TABLE 6-2 – LOCATION-BASED COSTS FOR WNCI

TECHNOLOGY: WNCI		
NOMINAL CAPACITY (ISO): 100,000 kW		
NOMINAL HEAT RATE (ISO): N/A Btu/kWh-HHV		
<u>Capital Cost Category</u>		<u>(000s) (August 19, 2016\$)</u>
Civil Structural Material and Installation		17,495
Mechanical Equipment Supply and Installation		126,892
Electrical / I&C Supply and Installation		12,633
Project Indirects ⁽¹⁾		6,610
EPC Cost before Contingency and Fee		163,630
Fee and Contingency		12,500
Total Project EPC		176,130
Owner Costs (excluding project finance)		10,568
Total Project Cost (excluding finance)		186,698
Total Project EPC	/ kW	1,761
Owner Costs 6% (excluding project finance)	/ kW	106
Total Project Cost (excluding project finance)	/ kW	1,867

(1) Includes engineering, distributable costs, scaffolding, construction management, and start-up.
(2) Total Project Costs excludes any transmission lines or utility interconnection facilities

The locational adjustments for the WNCI Facility are similar to those made for the WN Facility in the Submitted EIA April Report.

Table 6-3 in the Appendix presents the WNCI Facility capital cost variations for alternative U.S. plant locations, including the difference between the given location and the average location specified for the Cost Estimate.

6.5 O&M ESTIMATE

The O&M items for the WNCI Facility are slightly lower than those discussed in Section 14 of the Submitted EIA April Report for the WN Facility. Table 6-3 presents the FOM and VOM expenses

for the WNCI Facility. The WNCI Facility will deploy thirty-four 3 MW WTGs compared to fifty-six 1.79 MW WTGs for the WN Facility, resulting in a maintenance cost savings due to maintaining less WTGs. Conversely, the WNCI Facility will have higher wind speeds and the resulting higher mechanical loads on the WTGs deployed. The maintenance cost advantage of a lower WTG count will be partially offset by the additional maintenance costs resulting from higher mechanical loads at the WNCI Facility.

TABLE 6-3 – O&M EXPENSES FOR WNCI

TECHNOLOGY:	WN
Fixed O&M Expense	\$38.00/kW-year
Variable O&M Expense	\$0/MWh

6.6 ENVIRONMENTAL COMPLIANCE INFORMATION

Since wind utilizes a renewable energy source and no fuel is combusted to make power from an Onshore Wind Facility, air emissions are not created. Table 6-4 presents environmental emissions for the WNCI Facility.

TABLE 6-4 – ENVIRONMENTAL EMISSIONS FOR WNCI

TECHNOLOGY:	WNCI
NO_x	0 lb/ MMBtu
SO₂	0 lb/MMBtu
CO₂	0 lb/MMBtu

THIS PAGE INTENTIONALLY BLANK

7. BATTERY STORAGE 50 MW (BES-2)

7.1 MECHANICAL EQUIPMENT AND SYSTEMS

The Battery Storage 50MW (“BES-2”) Facility is rated at 50.0 MW and 400 MWh. The Facility configuration for the BES-2 is the same as Section 17 of the Submitted EIA April Report, with the exception that the duration of discharge is rated for eight hours of operation. Because of the long duration, lithium batteries included for this Report may not be suitable, and alternate technologies may have to be explored. Specific technologies and system designs would need to be identified from a competitive solicitation process prior to installation. Figure 7-1 presents a picture of a typical BES-2 Facility.

FIGURE 7-1 – BES-2 DESIGN CONFIGURATION

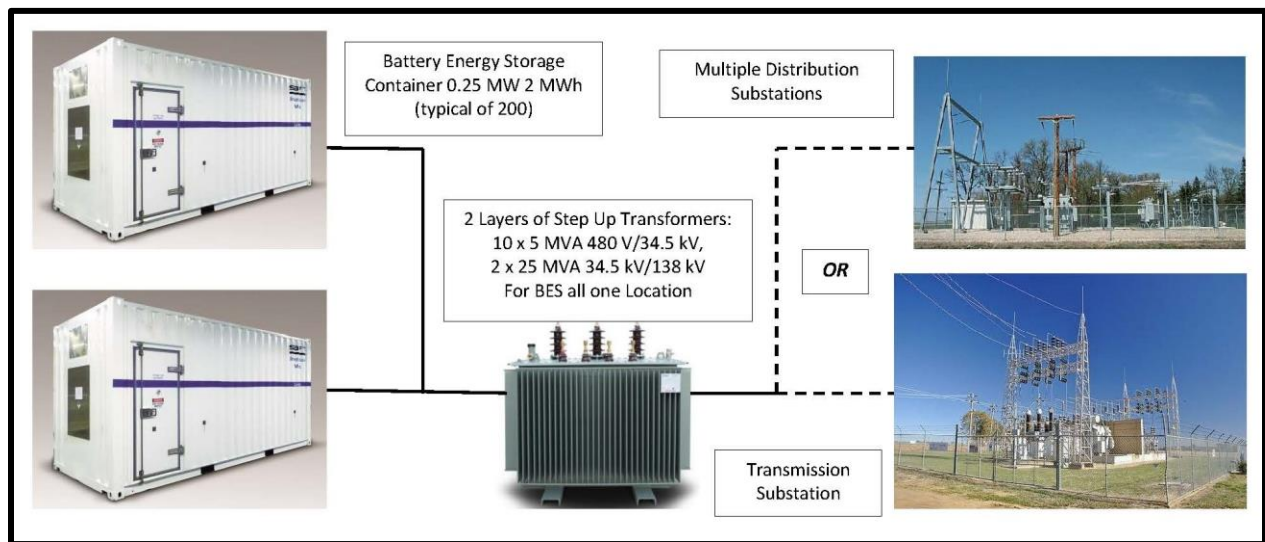

7.2 ELECTRICAL AND CONTROL SYSTEMS

The electrical and control systems for the BES-2 Facility are materially similar to the BES Facility in the Submitted EIA April Report.

7.3 OFF-SITE REQUIREMENTS

The off-site requirements for the BES-2 Facility are materially similar to the BES Facility in the Submitted EIA April Report.

7.4 CAPITAL COST ESTIMATE

The base Cost Estimate for the BES-2 Facility with a nominal capacity of 50 MW/400 MWh is \$3,122/kW. Table 7-1 summarizes the Cost Estimate categories for the BES-2 Facility.

TABLE 7-1 – LOCATION-BASED COSTS FOR BES-2

TECHNOLOGY: BES-2		
NOMINAL CAPACITY (ISO): 50,000 kW 400,000 kWh		
NOMINAL HEAT RATE (ISO): N/A Btu/kWh-HHV		
<u>Capital Cost Category</u>		<u>(000s) (August 15, 2016\$)</u>
Civil Structural Material and Installation		1,977
Mechanical Equipment Supply and Installation		115,993
Electrical / I&C Supply and Installation		5,694
Project Indirects ⁽¹⁾		7,819
EPC Cost before Contingency and Fee		131,483
Fee and Contingency		7,889
Total Project EPC		139,372
Owner Costs (excluding project finance)		16,725
Total Project Cost (excluding finance)		156,097
Total Project EPC	/ kW	2,787
Owner Costs 12% (excluding project finance)	/ kW	335
Total Project Cost (excluding project finance)	/ kW	3,122

(1) Includes engineering, distributable costs, scaffolding, construction management, and start-up.

The locational adjustments for the BES-2 Facility are similar to those made for the BES Facility in the Submitted EIA April Report.

Table 7-2 in the Appendix shows the BES-2 Facility capital cost variations for alternative U.S. plant locations, including the difference between the given location and the average location specified for the Cost Estimate.

7.5 O&M ESTIMATE

The O&M items for the BES-2 Facility are the same as those discussed in Section 17 of the Submitted EIA April Report for the BES Facility, with the exception that fluctuations may occur depending on the battery technology selected. Table 7-3 presents the O&M expenses for the BES-2 Facility.

TABLE 7-3 – O&M EXPENSES FOR BES-2

TECHNOLOGY:	BES-2
Fixed O&M Expense	\$40.00/kW-year
Variable O&M Expense	\$8.00/MWh

7.6 ENVIRONMENTAL COMPLIANCE INFORMATION

The BES-2 Facility produces no emissions on discharge; however, during charge, the ascribed emissions would be those of the charging generation source. The BES-2 requires 1.18 kWh of recharge for each 1.0 kWh discharged. This ratio may be as high as 1.43 for some of the flow technologies.

TABLE 7-4 – ENVIRONMENTAL EMISSIONS FOR BES-2

TECHNOLOGY:	BES
NO_x	0 lb/MMBtu
SO₂	0 lb/MMBtu
CO₂	0 lb/MMBtu

THIS PAGE INTENTIONALLY BLANK

APPENDIX 1 – STATE INFORMATION

**TABLE 3-2 – LOCATION-BASED COSTS FOR USC/CCS90 (650,000 KW)
(AUGUST 19, 2016 DOLLARS)**

State	City	Base Project Cost (\$/kW)	Location Variation	Delta Cost Difference (\$/kW)	Total Location Project Cost (\$/kW)
Alaska	Anchorage	5,569	21%	1,146	6,715
Alaska	Fairbanks	5,569	22%	1,218	6,787
Alabama	Huntsville	5,569	-10%	(534)	5,035
Arizona	Phoenix	5,569	-7%	(393)	5,176
Arkansas	Little Rock	5,569	-7%	(398)	5,171
California	Los Angeles	5,569	11%	620	6,189
California	Redding	5,569	6%	346	5,915
California	Bakersfield	5,569	6%	342	5,911
California	Sacramento	5,569	7%	396	5,965
California	San Francisco	5,569	23%	1,279	6,848
Colorado	Denver	5,569	-8%	(436)	5,133
Connecticut	Hartford	5,569	16%	884	6,453
Delaware	Dover	5,569	13%	751	6,320
District of Columbia	Washington	5,569	22%	1,228	6,797
Florida	Tallahassee	5,569	-9%	(484)	5,085
Florida	Tampa	5,569	-4%	(224)	5,345
Georgia	Atlanta	5,569	-10%	(532)	5,037
Hawaii	Honolulu	N/A	N/A	N/A	N/A
Idaho	Boise	5,569	-5%	(294)	5,275
Illinois	Chicago	5,569	12%	677	6,246
Indiana	Indianapolis	5,569	-1%	(63)	5,506
Iowa	Davenport	5,569	-2%	(110)	5,459
Iowa	Waterloo	5,569	-6%	(317)	5,252
Kansas	Wichita	5,569	-7%	(400)	5,169
Kentucky	Louisville	5,569	-7%	(379)	5,190
Louisiana	New Orleans	5,569	-12%	(647)	4,922
Maine	Portland	5,569	-6%	(320)	5,249
Maryland	Baltimore	5,569	-1%	(62)	5,507
Massachusetts	Boston	5,569	23%	1,279	6,848
Michigan	Detroit	5,569	2%	126	5,695
Michigan	Grand Rapids	5,569	-3%	(194)	5,375
Minnesota	Saint Paul	5,569	5%	285	5,854
Mississippi	Jackson	5,569	-7%	(416)	5,153

State	City	Base Project Cost (\$/kW)	Location Variation	Delta Cost Difference (\$/kW)	Total Location Project Cost (\$/kW)
Missouri	St. Louis	5,569	2%	86	5,655
Missouri	Kansas City	5,569	-1%	(29)	5,540
Montana	Great Falls	5,569	-4%	(222)	5,347
Nebraska	Omaha	5,569	-4%	(227)	5,342
New Hampshire	Concord	5,569	-3%	(180)	5,389
New Jersey	Newark	5,569	10%	558	6,127
New Mexico	Albuquerque	5,569	-5%	(272)	5,297
New York	New York	5,569	30%	1,651	7,220
New York	Syracuse	5,569	-2%	(133)	5,436
Nevada	Las Vegas	5,569	3%	166	5,735
North Carolina	Charlotte	5,569	-11%	(603)	4,966
North Dakota	Bismarck	5,569	-7%	(407)	5,162
Ohio	Cincinnati	5,569	-4%	(238)	5,331
Oregon	Portland	5,569	3%	142	5,711
Pennsylvania	Philadelphia	5,569	11%	635	6,204
Pennsylvania	Wilkes-Barre	5,569	-4%	(235)	5,334
Rhode Island	Providence	5,569	3%	148	5,717
South Carolina	Spartanburg	5,569	-13%	(718)	4,851
South Dakota	Rapid City	5,569	-9%	(518)	5,051
Tennessee	Knoxville	5,569	-10%	(531)	5,038
Texas	Houston	5,569	-10%	(579)	4,990
Utah	Salt Lake City	5,569	-6%	(309)	5,260
Vermont	Burlington	5,569	-7%	(374)	5,195
Virginia	Alexandria	5,569	4%	241	5,810
Virginia	Lynchburg	5,569	-5%	(275)	5,294
Washington	Seattle	5,569	5%	271	5,840
Washington	Spokane	5,569	-3%	(177)	5,392
West Virginia	Charleston	5,569	-2%	(110)	5,459
Wisconsin	Green Bay	5,569	-1%	(76)	5,493
Wyoming	Cheyenne	5,569	-1%	(65)	5,504
Puerto Rico	Cayey	N/A	N/A	N/A	N/A

**TABLE 4-2 – LOCATION-BASED COSTS FOR IGCC FACILITY (618,000 KW)
(AUGUST 19, 2016 DOLLARS)**

State	City	Base Project Cost (\$/kW)	Location Variation	Delta Cost Difference (\$/kW)	Total Location Project Cost (\$/kW)
Alaska	Anchorage	4,908	20%	966	5,874
Alaska	Fairbanks	4,908	19%	942	5,850
Alabama	Huntsville	4,908	-7%	(365)	4,543
Arizona	Phoenix	4,908	-5%	(247)	4,661
Arkansas	Little Rock	4,908	-5%	(250)	4,658
California	Los Angeles	4,908	12%	609	5,517
California	Redding	4,908	8%	376	5,284
California	Bakersfield	4,908	10%	467	5,375
California	Sacramento	4,908	8%	411	5,319
California	San Francisco	4,908	26%	1,281	6,189
Colorado	Denver	4,908	-6%	(289)	4,619
Connecticut	Hartford	4,908	17%	853	5,761
Delaware	Dover	4,908	15%	740	5,648
District of Columbia	Washington	4,908	26%	1,268	6,176
Florida	Tallahassee	4,908	-7%	(348)	4,560
Florida	Tampa	4,908	-3%	(164)	4,744
Georgia	Atlanta	4,908	-7%	(364)	4,544
Hawaii	Honolulu	N/A	N/A	N/A	N/A
Idaho	Boise	4,908	-3%	(171)	4,737
Illinois	Chicago	4,908	11%	517	5,425
Indiana	Indianapolis	4,908	0%	12	4,920
Iowa	Davenport	4,908	-2%	(78)	4,830
Iowa	Waterloo	4,908	-5%	(224)	4,684
Kansas	Wichita	4,908	-5%	(264)	4,644
Kentucky	Louisville	4,908	-5%	(249)	4,659
Louisiana	New Orleans	4,908	-9%	(463)	4,445
Maine	Portland	4,908	-3%	(151)	4,757
Maryland	Baltimore	4,908	1%	51	4,959
Massachusetts	Boston	4,908	21%	1,040	5,948
Michigan	Detroit	4,908	2%	108	5,016
Michigan	Grand Rapids	4,908	-3%	(137)	4,771
Minnesota	Saint Paul	4,908	4%	213	5,121
Mississippi	Jackson	4,908	-6%	(281)	4,627

State	City	Base Project Cost (\$/kW)	Location Variation	Delta Cost Difference (\$/kW)	Total Location Project Cost (\$/kW)
Missouri	St. Louis	4,908	3%	154	5,062
Missouri	Kansas City	4,908	0%	17	4,925
Montana	Great Falls	4,908	-3%	(147)	4,761
Nebraska	Omaha	4,908	-3%	(142)	4,766
New Hampshire	Concord	4,908	-2%	(90)	4,818
New Jersey	New ark	4,908	8%	413	5,321
New Mexico	Albuquerque	4,908	-3%	(168)	4,740
New York	New York	4,908	19%	929	5,837
New York	Syracuse	4,908	6%	315	5,223
Nevada	Las Vegas	4,908	4%	174	5,082
North Carolina	Charlotte	4,908	-8%	(389)	4,519
North Dakota	Bismarck	4,908	-6%	(287)	4,621
Ohio	Cincinnati	4,908	-2%	(111)	4,797
Oregon	Portland	4,908	5%	232	5,140
Pennsylvania	Philadelphia	4,908	6%	303	5,211
Pennsylvania	Wilkes-Barre	4,908	-3%	(129)	4,779
Rhode Island	Providence	4,908	3%	142	5,050
South Carolina	Spartanburg	4,908	-10%	(476)	4,432
South Dakota	Rapid City	4,908	-7%	(367)	4,541
Tennessee	Knoxville	4,908	-7%	(357)	4,551
Texas	Houston	4,908	-8%	(409)	4,499
Utah	Salt Lake City	4,908	-3%	(125)	4,783
Vermont	Burlington	4,908	-5%	(227)	4,681
Virginia	Alexandria	4,908	6%	303	5,211
Virginia	Lynchburg	4,908	-3%	(138)	4,770
Washington	Seattle	4,908	7%	323	5,231
Washington	Spokane	4,908	-2%	(88)	4,820
West Virginia	Charleston	4,908	-1%	(59)	4,849
Wisconsin	Green Bay	4,908	0%	(16)	4,892
Wyoming	Cheyenne	4,908	1%	72	4,980
Puerto Rico	Cayey	4,908	-3%	(136)	4,772

**TABLE 5-2 – LOCATION-BASED COSTS FOR ANGF FACILITY (2,234,000 KW)
(AUGUST 19, 2016 DOLLARS)**

State	City	Base Project Cost (\$/kW)	Location Variation	Delta Cost Difference (\$/kW)	Total Location Project Cost (\$/kW)
Alaska	Anchorage	6,384	12%	787	7,171
Alaska	Fairbanks	6,384	13%	799	7,183
Alabama	Huntsville	6,384	-4%	(227)	6,157
Arizona	Phoenix	6,384	-2%	(156)	6,228
Arkansas	Little Rock	6,384	-2%	(158)	6,226
California	Los Angeles	6,384	7%	469	6,853
California	Redding	6,384	4%	277	6,661
California	Bakersfield	6,384	5%	332	6,716
California	Sacramento	6,384	5%	299	6,683
California	San Francisco	6,384	16%	1,028	7,412
Colorado	Denver	6,384	-3%	(174)	6,210
Connecticut	Hartford	6,384	12%	772	7,156
Delaware	Dover	6,384	11%	704	7,088
District of Columbia	Washington	6,384	20%	1,280	7,664
Florida	Tallahassee	6,384	-3%	(217)	6,167
Florida	Tampa	6,384	-2%	(106)	6,278
Georgia	Atlanta	6,384	-4%	(226)	6,158
Hawaii	Honolulu	N/A	N/A	N/A	N/A
Idaho	Boise	6,384	-2%	(103)	6,281
Illinois	Chicago	6,384	6%	362	6,746
Indiana	Indianapolis	6,384	1%	59	6,443
Iowa	Davenport	6,384	-1%	(47)	6,337
Iowa	Waterloo	6,384	-2%	(135)	6,249
Kansas	Wichita	6,384	-2%	(159)	6,225
Kentucky	Louisville	6,384	-2%	(150)	6,234
Louisiana	New Orleans	6,384	-4%	(286)	6,098
Maine	Portland	6,384	-1%	(39)	6,345
Maryland	Baltimore	6,384	2%	134	6,518
Massachusetts	Boston	6,384	14%	884	7,268
Michigan	Detroit	6,384	1%	64	6,448
Michigan	Grand Rapids	6,384	-1%	(83)	6,301
Minnesota	Saint Paul	6,384	2%	143	6,527
Mississippi	Jackson	6,384	-3%	(177)	6,207

State	City	Base Project Cost (\$/kW)	Location Variation	Delta Cost Difference (\$/kW)	Total Location Project Cost (\$/kW)
Missouri	St. Louis	6,384	1%	92	6,476
Missouri	Kansas City	6,384	0%	10	6,394
Montana	Great Falls	6,384	-1%	(89)	6,295
Nebraska	Omaha	6,384	-1%	(85)	6,299
New Hampshire	Concord	6,384	-1%	(54)	6,330
New Jersey	New ark	6,384	4%	248	6,632
New Mexico	Albuquerque	6,384	-1%	(93)	6,291
New York	New York	6,384	9%	557	6,941
New York	Syracuse	6,384	5%	345	6,729
Nevada	Las Vegas	6,384	2%	130	6,514
North Carolina	Charlotte	6,384	-4%	(233)	6,151
North Dakota	Bismarck	6,384	-3%	(173)	6,211
Ohio	Cincinnati	6,384	0%	(15)	6,369
Oregon	Portland	6,384	3%	191	6,575
Pennsylvania	Philadelphia	6,384	3%	181	6,565
Pennsylvania	Wilkes-Barre	6,384	-1%	(77)	6,307
Rhode Island	Providence	6,384	1%	85	6,469
South Carolina	Spartanburg	6,384	-5%	(294)	6,090
South Dakota	Rapid City	6,384	-3%	(220)	6,164
Tennessee	Knoxville	6,384	-3%	(214)	6,170
Texas	Houston	6,384	-4%	(246)	6,138
Utah	Salt Lake City	6,384	-1%	(75)	6,309
Vermont	Burlington	6,384	-2%	(137)	6,247
Virginia	Alexandria	6,384	5%	338	6,722
Virginia	Lynchburg	6,384	0%	(31)	6,353
Washington	Seattle	6,384	4%	246	6,630
Washington	Spokane	6,384	-1%	(53)	6,331
West Virginia	Charleston	6,384	-1%	(36)	6,348
Wisconsin	Green Bay	6,384	1%	42	6,426
Wyoming	Cheyenne	6,384	3%	178	6,562
Puerto Rico	Cayey	N/A	N/A	N/A	N/A

**TABLE 6-2 – LOCATION-BASED COSTS FOR WNCI FACILITY (100,000 KW)
(AUGUST 19, 2016 DOLLARS)**

State	City	Base Project Cost (\$/kW)	Location Variation	Delta Cost Difference (\$/kW)	Total Location Project Cost (\$/kW)
Alaska	Anchorage	1,867	30%	560	2,427
Alaska	Fairbanks	1,867	56%	1,044	2,911
Alabama	Huntsville	1,867	-5%	(97)	1,770
Arizona	Phoenix	1,867	-3%	(61)	1,806
Arkansas	Little Rock	1,867	-3%	(56)	1,811
California	Los Angeles	1,867	15%	279	2,146
California	Redding	1,867	12%	220	2,087
California	Bakersfield	1,867	14%	254	2,121
California	Sacramento	1,867	12%	222	2,089
California	San Francisco	1,867	21%	386	2,253
Colorado	Denver	1,867	3%	49	1,916
Connecticut	Hartford	1,867	8%	156	2,023
Delaware	Dover	1,867	6%	110	1,977
District of Columbia	Washington	1,867	10%	195	2,062
Florida	Tallahassee	1,867	-4%	(81)	1,786
Florida	Tampa	1,867	-3%	(63)	1,804
Georgia	Atlanta	1,867	-5%	(97)	1,770
Hawaii	Honolulu	1,867	35%	650	2,517
Idaho	Boise	1,867	5%	98	1,965
Illinois	Chicago	1,867	14%	261	2,128
Indiana	Indianapolis	1,867	-1%	(12)	1,855
Iowa	Davenport	1,867	6%	115	1,982
Iowa	Waterloo	1,867	4%	69	1,936
Kansas	Wichita	1,867	3%	61	1,928
Kentucky	Louisville	1,867	-4%	(69)	1,798
Louisiana	New Orleans	1,867	-7%	(128)	1,739
Maine	Portland	1,867	7%	138	2,005
Maryland	Baltimore	1,867	1%	27	1,894
Massachusetts	Boston	1,867	11%	201	2,068
Michigan	Detroit	1,867	3%	48	1,915
Michigan	Grand Rapids	1,867	-1%	(18)	1,849
Minnesota	Saint Paul	1,867	11%	198	2,065
Mississippi	Jackson	1,867	-3%	(64)	1,803

State	City	Base Project Cost (\$/kW)	Location Variation	Delta Cost Difference (\$/kW)	Total Location Project Cost (\$/kW)
Missouri	St. Louis	1,867	3%	56	1,923
Missouri	Kansas City	1,867	0%	9	1,876
Montana	Great Falls	1,867	8%	154	2,021
Nebraska	Omaha	1,867	5%	92	1,959
New Hampshire	Concord	1,867	8%	155	2,022
New Jersey	Newark	1,867	10%	186	2,053
New Mexico	Albuquerque	1,867	4%	75	1,942
New York	New York	1,867	25%	467	2,334
New York	Syracuse	1,867	0%	-	1,867
Nevada	Las Vegas	1,867	9%	166	2,033
North Carolina	Charlotte	1,867	-6%	(107)	1,760
North Dakota	Bismarck	1,867	4%	80	1,947
Ohio	Cincinnati	1,867	-4%	(67)	1,800
Oregon	Portland	1,867	9%	171	2,038
Pennsylvania	Philadelphia	1,867	5%	92	1,959
Pennsylvania	Wilkes-Barre	1,867	-2%	(33)	1,834
Rhode Island	Providence	1,867	3%	59	1,926
South Carolina	Spartanburg	1,867	-7%	(127)	1,740
South Dakota	Rapid City	1,867	2%	36	1,903
Tennessee	Knoxville	1,867	-5%	(101)	1,766
Texas	Houston	1,867	-6%	(118)	1,749
Utah	Salt Lake City	1,867	6%	112	1,979
Vermont	Burlington	1,867	6%	109	1,976
Virginia	Alexandria	1,867	3%	63	1,930
Virginia	Lynchburg	1,867	-4%	(69)	1,798
Washington	Seattle	1,867	4%	67	1,934
Washington	Spokane	1,867	6%	109	1,976
West Virginia	Charleston	1,867	0%	4	1,871
Wisconsin	Green Bay	1,867	-2%	(42)	1,825
Wyoming	Cheyenne	1,867	3%	62	1,929
Puerto Rico	Cayey	1,867	9%	167	2,034

**TABLE 7-2 – LOCATION-BASED COSTS FOR BES-2 FACILITY (50,000 KW)
(AUGUST 19, 2016 DOLLARS)**

State	City	Base Project Cost (\$/kW)	Location Variation	Delta Cost Difference (\$/kW)	Total Location Project Cost (\$/kW)
Alaska	Anchorage	3,122	16%	490	3,612
Alaska	Fairbanks	3,122	28%	861	3,983
Alabama	Huntsville	3,122	-2%	(53)	3,069
Arizona	Phoenix	3,122	-1%	(33)	3,089
Arkansas	Little Rock	3,122	-1%	(30)	3,092
California	Los Angeles	3,122	6%	196	3,318
California	Redding	3,122	2%	48	3,170
California	Bakersfield	3,122	2%	66	3,188
California	Sacramento	3,122	2%	50	3,172
California	San Francisco	3,122	8%	240	3,362
Colorado	Denver	3,122	-1%	(44)	3,078
Connecticut	Hartford	3,122	4%	123	3,245
Delaware	Dover	3,122	3%	95	3,217
District of Columbia	Washington	3,122	6%	195	3,317
Florida	Tallahassee	3,122	-1%	(44)	3,078
Florida	Tampa	3,122	-1%	(34)	3,088
Georgia	Atlanta	3,122	-2%	(52)	3,070
Hawaii	Honolulu	3,122	28%	880	4,002
Idaho	Boise	3,122	-1%	(17)	3,105
Illinois	Chicago	3,122	3%	80	3,202
Indiana	Indianapolis	3,122	0%	2	3,124
Iowa	Davenport	3,122	0%	(8)	3,114
Iowa	Waterloo	3,122	-1%	(33)	3,089
Kansas	Wichita	3,122	-1%	(37)	3,085
Kentucky	Louisville	3,122	-1%	(38)	3,084
Louisiana	New Orleans	3,122	-2%	(69)	3,053
Maine	Portland	3,122	-1%	(22)	3,100
Maryland	Baltimore	3,122	2%	53	3,175
Massachusetts	Boston	3,122	5%	147	3,269
Michigan	Detroit	3,122	0%	15	3,137
Michigan	Grand Rapids	3,122	-1%	(20)	3,102
Minnesota	Saint Paul	3,122	1%	46	3,168
Mississippi	Jackson	3,122	-1%	(34)	3,088

State	City	Base Project Cost (\$/kW)	Location Variation	Delta Cost Difference (\$/kW)	Total Location Project Cost (\$/kW)
Missouri	St. Louis	3,122	1%	30	3,152
Missouri	Kansas City	3,122	0%	5	3,127
Montana	Great Falls	3,122	1%	40	3,162
Nebraska	Omaha	3,122	-1%	(21)	3,101
New Hampshire	Concord	3,122	0%	3	3,125
New Jersey	Newark	3,122	2%	65	3,187
New Mexico	Albuquerque	3,122	-1%	(30)	3,092
New York	New York	3,122	17%	537	3,659
New York	Syracuse	3,122	0%	(11)	3,111
Nevada	Las Vegas	3,122	1%	19	3,141
North Carolina	Charlotte	3,122	-2%	(58)	3,064
North Dakota	Bismarck	3,122	-1%	(18)	3,104
Ohio	Cincinnati	3,122	-1%	(36)	3,086
Oregon	Portland	3,122	1%	22	3,144
Pennsylvania	Philadelphia	3,122	2%	49	3,171
Pennsylvania	Wilkes-Barre	3,122	-1%	(18)	3,104
Rhode Island	Providence	3,122	1%	31	3,153
South Carolina	Spartanburg	3,122	-2%	(69)	3,053
South Dakota	Rapid City	3,122	-1%	(31)	3,091
Tennessee	Knoxville	3,122	-2%	(54)	3,068
Texas	Houston	3,122	-2%	(64)	3,058
Utah	Salt Lake City	3,122	0%	(10)	3,112
Vermont	Burlington	3,122	0%	(12)	3,110
Virginia	Alexandria	3,122	0%	(8)	3,114
Virginia	Lynchburg	3,122	-1%	(37)	3,085
Washington	Seattle	3,122	1%	36	3,158
Washington	Spokane	3,122	0%	(11)	3,111
West Virginia	Charleston	3,122	1%	21	3,143
Wisconsin	Green Bay	3,122	0%	(3)	3,119
Wyoming	Cheyenne	3,122	-1%	(17)	3,105
Puerto Rico	Cayey	3,122	6%	180	3,302